

Datasheet • FEE-5-12

4th generation a-Si solar panels

Reliable cell technology

Free Energy produces stable and reliable amorphous silicon cells. After initial stabilization during the first two months of outdoor use, the amorphous silicon cell will be stable for decades.

The expected lifetime of the advanced amorphous silicon solar cells is at least 20 years.

High energy yield

The amorphous silicon solar cells, produced by Free Energy, function better than crystalline silicon solar cells in partial or indirect sunlight. Tests have shown that the annual energy output is approximately 15% higher per rated Watt-peak power.

Outdoor performance

The outdoor performance of amorphous silicon solar panels depends primarily on their protection against corrosion.

Free Energy applies an *injected* polymer frame, with a very high moisture barrier. This technology has been developed internally and is unique to the Free Energy products.

*This advanced technology makes our solar panels reliable for outdoor use with **10 years guarantee** on power output.*



free energy europe

Address: Parc de la Croisette • 2, Rue Léon Droux, B.P. 66 • 62302 Lens Cedex • France

Email: info@freeenergyeurope.com • Website: www.freeenergyeurope.com

Telephone: +33 (0)3 21 79 30 60 • Fax: +33 (0)3 21 43 65 88

03/2008

N° SIRET: 49125885100014 • Code APE: 4669B • S.A.S. au Capital de 237 000 € • N° TVA: FR 81491258851

Due to ongoing improvement policy, this documentation is subject to modification without prior notice.

Datasheet • FEE-5-12 Solar Panel

Specifications

Main characteristics panel

Cell technology	Single junction amorphous silicon
Panel technology	4 th generation framing
Encapsulation	Glass-to-glass encapsulation with moulded polymer injection framing
Expected lifetime	20 years minimum
Operating conditions	-40 °C to +85 °C

Electrical characteristics - at Standard Test Conditions ¹	Maximum power	Stabilized power
Maximum output power	5.0 Watt peak	4.0 Watt peak
Maximum current at 16 V	0.29 Ampere	0.25 Ampere
Short circuit current	0.35 Ampere	0.30 Ampere
Open circuit voltage	22.0 Volts	22.0 Volts

1) Data refers to Standard Test Conditions (STC), an approximation of operation in full sunlight (STC: 1000 W/m² irradiance, 25 °C cell temperature, spectrum AM 1.5). Rated parameters may vary +/- 10%.

Electrical characteristics - at Average Operating Conditions ²	Stabilized power
Equivalent yield peak power	4.6 Watt peak

2) Data refers to real annual average irradiation in the Netherlands, normalized on average performance of crystalline silicon technology. Rated parameters may vary +/- 10%.

Temperature coefficients

Voltage	- 0.29% / °C
Current	+ 0.08% / °C
Normal operating cell temperature	45 °C (at 800 W/m ² , ambient temperature 21 °C)

Dimensions

Dimensions (H x W)	343 mm x 317 mm
Thickness	12.5 mm
Weight	1.5 kg

Connections

Cable	1 m double insulated cable (2 x 0.75 mm ²)
Polarity	Brown = +, Blue = -
Fixing	4 holes for easy installation (using M6 screws or bolts)

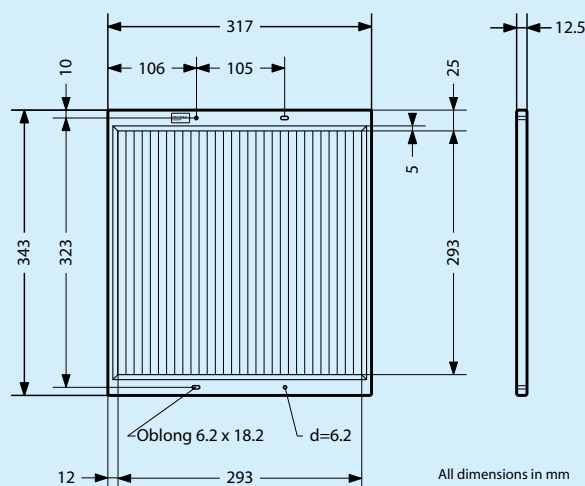

March 2008

free energy europe

Address: Parc de la Croisette • 2, Rue Léon Droux, B.P. 66 • 62302 Lens Cedex • France

Email: info@freeenergyeurope.com • Website: www.freeenergyeurope.com

Telephone: +33 (0)3 21 79 30 60 • Fax: +33 (0)3 21 43 65 88